

DIMENSIONS ARE IN MILLIMETERS

STANDARD CV JOINTS

Ø108=28 SPLINES M10 BOLT FIXINGS } STANDARD SPLINES  
 Ø100=25 SPLINES M8 BOLT FIXINGS }  
 SAMPLES ARE REQUIRED FOR ANY  
 NON STANDARD SPLINES

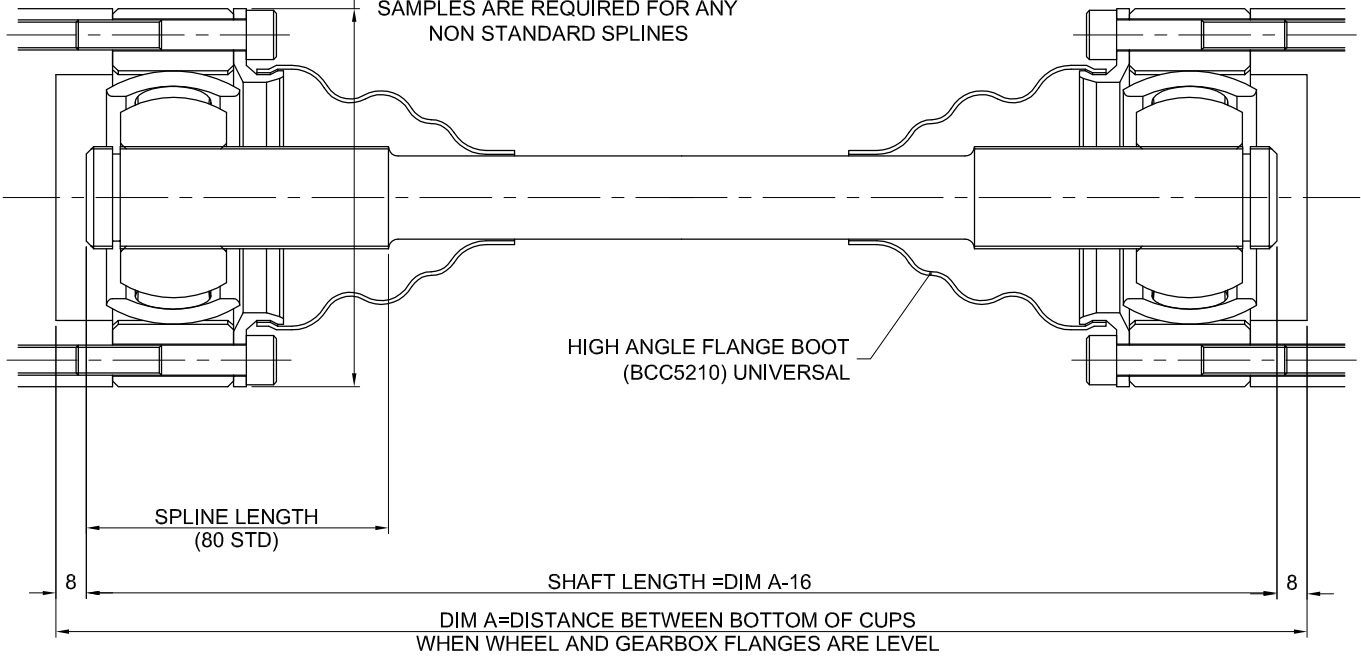

WHEN ORDERING NONE STANDARD DRIVESHAFTS PLEASE SEND US THE CV JOINTS YOU WISH TO USE AND AN OLD DRIVESHAFT AS SAMPLES. SEND US THIS DRAWING WITH AS MANY DIMENSIONS AS YOU CAN. ALSO INCLUDE YOUR NAME ADDRESS AN TELEPHONE NUMBER. ANY OTHER QUESTIONS PLEASE CONTACT US.

USING STANDARD FLANGES AND CAGES YOU GET 17° OF TRAVEL

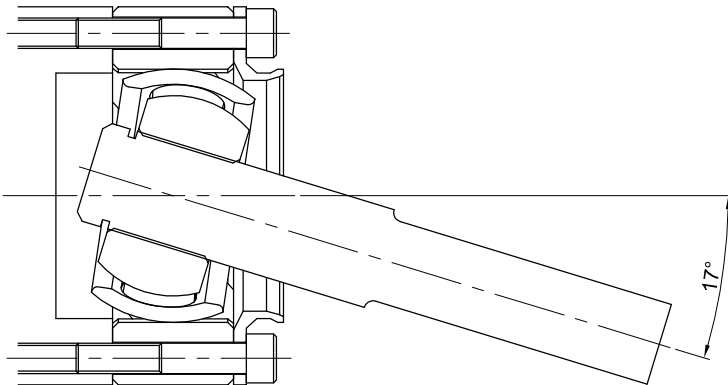

USING HIGH ANGLE FLANGES AND RACE CAGES YOU GET 27° OF TRAVEL

